

COAST

C O A S T
C O N T R O L S



Web Guiding Machine Solutions

Guiding You Since 1992!



Coast Controls was established in 1992 by William and Douglas Fife, who had many years of web guiding experience. Kyle Koontz has worked for Coast Controls since 2006 and has been President of Coast Controls since 2019.

The company operates from a modern facility in Sarasota, Florida, and utilizes state of the art CNC machining centers and other manufacturing technology in their operation.

Coast Controls is the exclusive manufacturer of a simplified and unique All-Air Automatic Web Guiding Systems, electromechanical web guiding systems, and a manufacturer of complete turnkey winders that meet the needs of a wide variety of applications.

The **All-Air system** is based on a proportional All-Air Servo Controller, which operates entirely on low-pressure plant air. The Servo Controller works with an Airflow sensor, Air Cylinder, and a properly designed and applied intermediate or unwind guide to align the material's moving web accurately.

The All-Air system's key features include:

- a 10-year warranty
- explosion-proof
- no maintenance
- no electricity
- pinpoint accuracy
- long-lasting dependability



The **Electromechanical** web guiding system supported by a Selectra SRL web controller utilizes a user-friendly operator panel with an LCD touchscreen display. The correction signal leads to an electrical actuator, and the measured error is controlled by either reflective photocells, ultrasonic sensors, or infrared sensors.

The Electromechanical system key features include:

- a 1-year warranty
- guiding from a printed line or registration mark
- PID algorithm to accelerate the reaction of the system
- correction of the dead zone
- compact actuators with forces up to 7000 Newtons (1,573 lbs.)



Many original equipment manufacturers incorporate Coast systems on the machines they design and build.

To adopt a perfect design for your application, Coast utilizes SolidWorks 3D Software, which can be converted to just about any format so the customer can place the 3D model of the guide right into their design, saving time and money.

Although we carry standard guiding systems to fit most machines in the converting industry, we will modify our designs to adapt to your machine, so installing a new Coast guide is just like replacing the original - and Coast will do this at no extra charge to you.

TABLE OF CONTENTS

How All-Air Works	4	Retrofit	17
Types of Web Guides	5	Roll Stands Controls	18
Turnkey Solutions	6	All-Air Questions	19
Displacement Guides	8	Electric Guides	20
Steering Guides	12	Additional Products	22
Winding Guides	15	Idler Rollers	25

COAST CONTROLS ALL-AIR BENEFITS

Since 1992 Coast Controls, Inc. manufactures the world’s most reliable and simplistic web guiding system on the market. Listed below are some of the advantages Coast Controls’ All-Air Guiding System offers over other web guiding systems!



Dependability: Pneumatics are renowned for their reliability, which means less downtime and more production. That’s why an unprecedented **10-year warranty** covers our All-Air web guide systems.



Uniformity: One sensor for all materials. It doesn’t matter if it’s opaque, translucent, reflective, or even transparent; our airflow sensor will detect any material that disrupts the signal air stream.



No Electricity: There is no electricity or electrical components with the potential to “burn out,” such as controllers, motors, switches, circuit boards—hence fewer spare parts needed in your inventory.



Simplicity: The Coast systems are simple to install, operate, and maintain. We use the same controller on every system we build. Once you know how to work one, you know how to manage any guiding system we make.



Accuracy: Guiding results are 100% satisfaction guaranteed on all applications.



No Explosions: Our systems are inherently explosion-proof right out of the crate.



Dust & Dirt Friendly: Our guide systems are not affected by dusty or dirty production environments and perform well in high heat or humid areas.



No Routine Maintenance: No lubrication or preventative maintenance required. The Filter Package’s pop-up indicator let’s you know when to replace filter elements.



Excellent ROI: Our web guides and rollers ultimately reduce your production costs and downtime.



Self Cleaning: The airflow edge sensor orifices have positive airflow on both sides! No Vacuum!

HOW ALL-AIR WORKS

Plant air connects to the friction-free servo controller through a two-stage cartridge/coalescing air filter and precision low-pressure regulator/gauge.

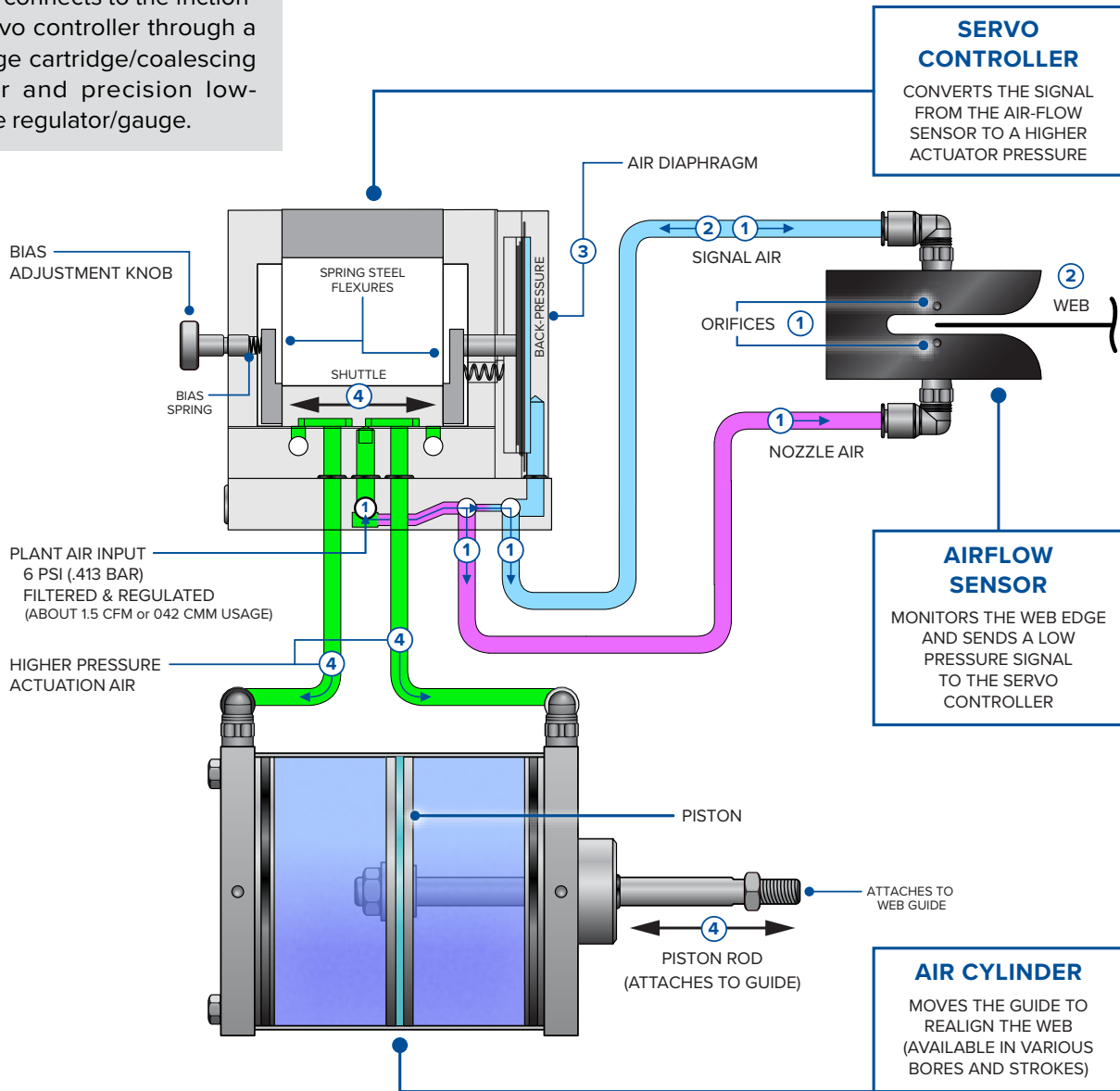

- 1** A small portion of the air reduces in pressure before going to both sides of the airflow sensor. Air continually bleeds from the sensor's opposing nozzle and signal orifices, keeping them free of dust and other foreign matter.
- 2** As web misalignment occurs, the edge of the web moves in or out of the sensor. This causes the slightly higher nozzle air pressure to increase or decrease the back-pressure in the signal air coming from the servo controller.
- 3** The change in pressure creates an imbalance between the air diaphragm's opposing forces and the bias spring in the servo controller, causing the shuttle to move.
- 4** The shuttle movement directs the higher pressure actuation air to the proper end of the air cylinder. This causes the cylinder piston rod to move the guide to the precise amount required to realign the web at the sensor.

With the web edge back in its proper position at the sensor, the guiding system is again balanced, completing the control loop. Sensing and correction continue to take place as misalignment occurs.

TYPES OF WEB GUIDES

All web guiding systems should be installed as close to the incoming side of the converting process where accuracy is needed. The location of the guide will determine if you will be using a **Shifting Unwind Stand**, **Intermediate Displacement Guide**, **Intermediate Steering Guide**, or a **Shifting Rewind Stand**.

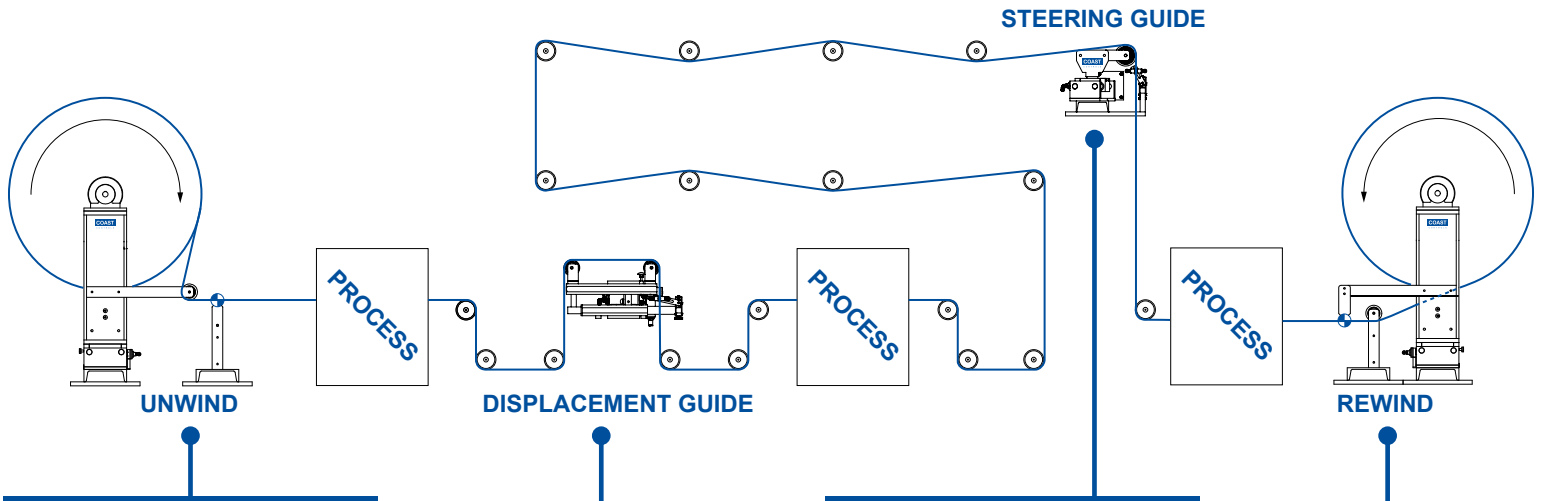

UNWIND GUIDING

is obtained by automatically positioning an unwinding roll of material mounted on a laterally shifting roll stand. A shifting idler roller is attached to the stand. The sensor is fixed and mounted independently of the stand.

DISPLACEMENT GUIDES

correct web misalignment (error) by pivoting a set of guide rollers about a fixed point to geometrically displace (align) the web. A displacement guide provides correction with minimal entry and exit span requirements. Displacement guides are ideal for applications with space limitations.

STEERING GUIDES

correct by moving the web laterally while simultaneously pivoting the web in the same direction. This offsets the web's inclination to return to its prior position. The guide (single or double roller) must be installed after a long, free-entering span to avoid wrinkling.

REWIND GUIDING

(chasing) provides edge position controls by having the shifting stand and attached sensor 'chase' any web misalignment as the roll is winding. A fixed idler roller is required between the sensor and the rewinding roll.

INDUSTRIES WE SERVE:



PAPER & PLASTIC BAGS



ENVELOPE MANUFACTURERS



LABEL MANUFACTURERS



FLEXOGRAPHIC PRINTING



TIRE & RUBBER MANUFACTURERS



FLEXIBLE PACKAGING



EXTRUDED PLASTIC & METALIZED FILM



COATING & LAMINATING



NON-WOVENS



DIE CUTTING



PHARMACEUTICAL PACKAGING



FOOD PACKAGING



SLITTING

ROLL-TO-ROLL TURNKEY SOLUTIONS

Coast Controls, Inc. manufactures cost-effective and straightforward **Turnkey Solutions** for nearly any application.

With three decades of experience producing the world's most trusted web guides, we now incorporate custom made units onto expertly designed Unwinds, Rewinds, and Roll-To-Roll web handling systems.

Building complete converting and inspection machines out of proven, flexible components to get you to market faster.



Roll-To-Roll Heavy-Duty Inspection Machine



Roll-To-Roll Custom Cantilevered R&D Machines

ROLL-TO-ROLL TURNKEY SOLUTIONS

Roll-To-Roll Cantilevered Machine



Custom Cantilevered Unwind System



Triple Shifting Unwinder for N95 Masks

DISPLACEMENT GUIDES



MDG5-1815-4R-CG2

Displacement Guides correct web misalignment (error) by pivoting a set of rollers about a fixed point to geometrically align (or displace) the web.

They provide correction with minimal entry and exit span requirements making them ideal for applications with space limitations.

WEB PATH CONFIGURATIONS

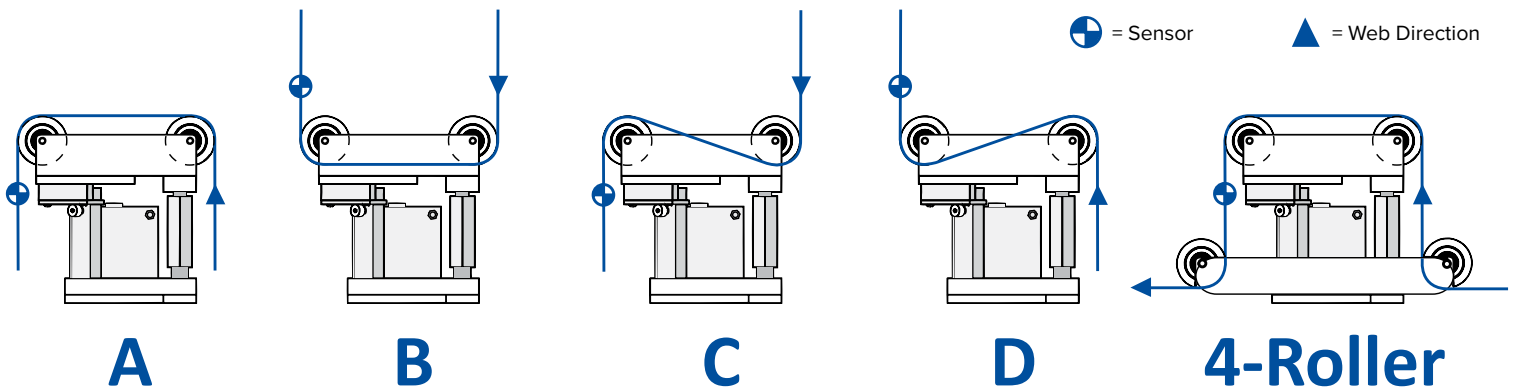

REQUIREMENTS FOR DISPLACEMENT GUIDE APPLICATION

- Entry and exit spans must be parallel to each other and perpendicular to the plane of the guide's motion
- Web must enter and exit the guide at a 90° angle
- Guide span should be approximately 1x the maximum web width
- The airflow sensor must be securely mounted after the guide's exit roller and within the first one-third of the exit span
- At least one idler roller must be located between the exiting guide roller and the process (printing, laminating, etc.)

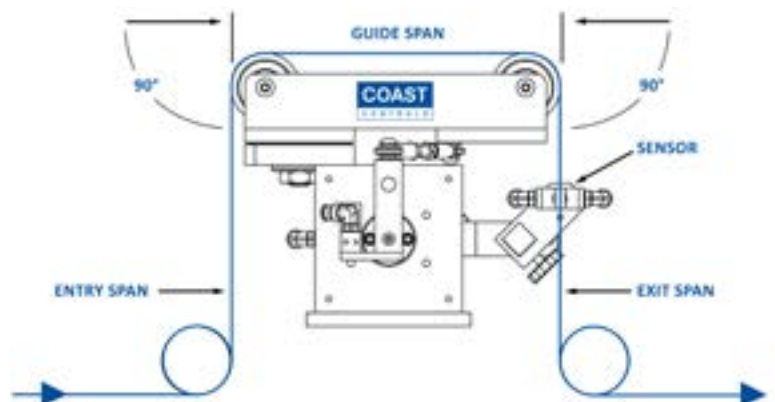

Our **MDG** models come equipped with solid aluminum plate construction, clear anodized finish, stainless steel hardware, low friction ER style bearings and Auto Centering. Special features are available upon request.



MDG3

Web widths up to 4 in (101.6mm)

Roll Face	5 in to 6 in (127 – 152.4mm)
Guide Span	5 in to 6 in (127 – 152.4mm)
Roller Diameter	1.5 in to 2 in (38.1 – 50.8mm)

The **MDG3** web guiding systems feature a 3 inch (76mm) actuator and either a 2 or more roller configuration and are designed for narrow web applications up to 4 inches (101.6mm).



MDG4

Web widths up to 8 in (203.2mm)

Roll Face	7 in to 10 in (177.8 – 254mm)
Guide Span	8 in to 10 in (203.2 – 254mm)
Roller Diameter	1.5 in to 2.5 in (38.1 – 63.5mm)

The **MDG4** web guiding systems feature a 4 inch (101.6mm) actuator and either a 2 or more roller configuration and are designed for narrow web applications up to 8 inches (203.2mm).



MDG5

Web widths up to 13 in (330.2mm)

Roll Face	8 in to 15 in (203.2 – 381mm)
Guide Span	10 in to 12 in (254 – 304.8mm)
Roller Diameter	2.5 in to 3 in (63.5 – 76.2mm)

The **MDG5** web guiding systems features a 5 inch (127mm) actuator and either a 2 or more roller configuration and are designed for narrow web applications up to 13 inch (330.2mm).

RIGID AND CUSTOM DISPLACEMENT GUIDES



RDG5
Washdown

RDG5
Web widths up to 26 in (660.4mm)

Roll Face	20 in to 30 in (508 – 762mm)
Guide Span	16 in to 25 in (406.4 – 635mm)
Roller Diameter	3 in to 4 in (76.2 – 101.6mm)

Our **Rigid** and **Custom Displacement Guide** systems are engineered with a 2 and 4-point suspension system, which offers the ultimate in support for medium to heavy duty applications.

RDG5 models are equipped with solid aluminum plate construction, clear anodized finish, stainless steel hardware, low friction ER style bearings, and Auto Centering.

CD guides come with stainless steel hardware, low friction ER style bearings, and Auto Centering.

Special features are available upon request for both of these models.

CD2
Web widths up to 35 in (889mm)

Roll Face	34 in to 40 in (863.6 – 1016mm)
Guide Span	20 in to 30 in (508 – 762mm)
Roller Diameter	3 in to 4 in (76.2 – 101.6mm)

CD4
Web widths up to 130 in (3302mm)

Roll Face	45 in to 140 in (1143 – 3556mm)
Guide Span	20 in to 75 in (508 – 1905mm)
Roller Diameter	3 in to 8 in (76.2 – 203.2mm)



CD2 ST2



CD4-4530

DISPLACEMENT GUIDE APPLICATIONS

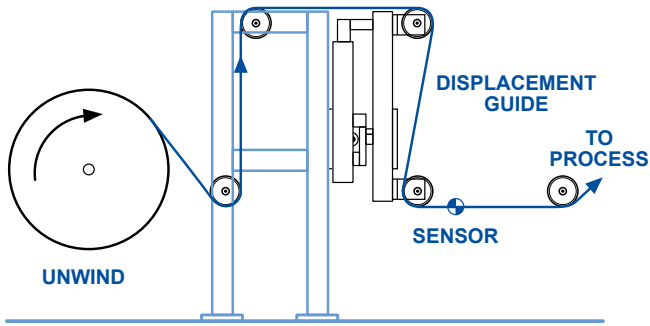

GUIDING INTO PROCESS

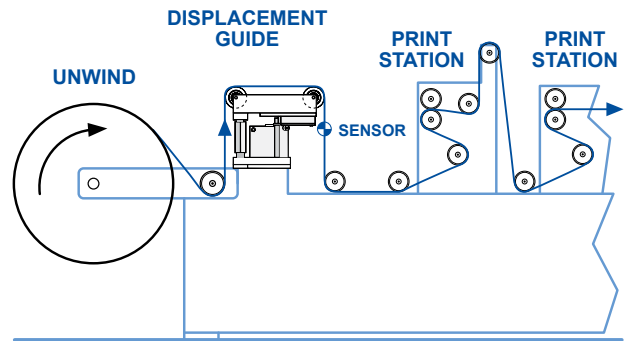

GUIDING INTO PRINTING ON A NARROW WEB PRESS

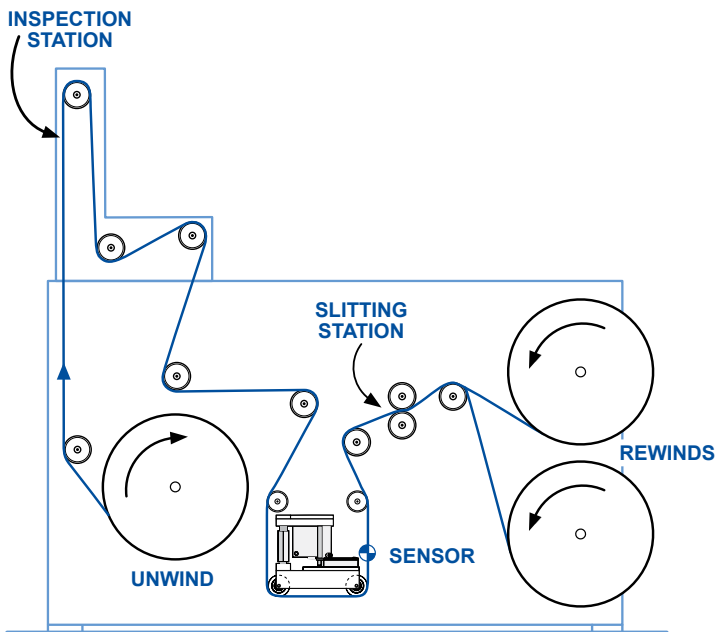

GUIDING ON A SLITTER / REWINDER / INSPECTION MACHINE

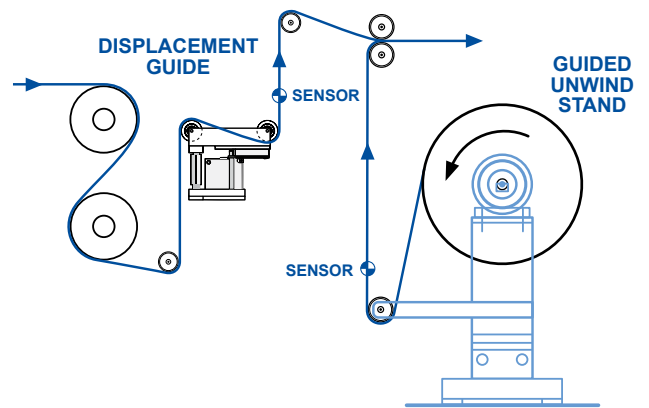

GUIDING INTO LAMINATING

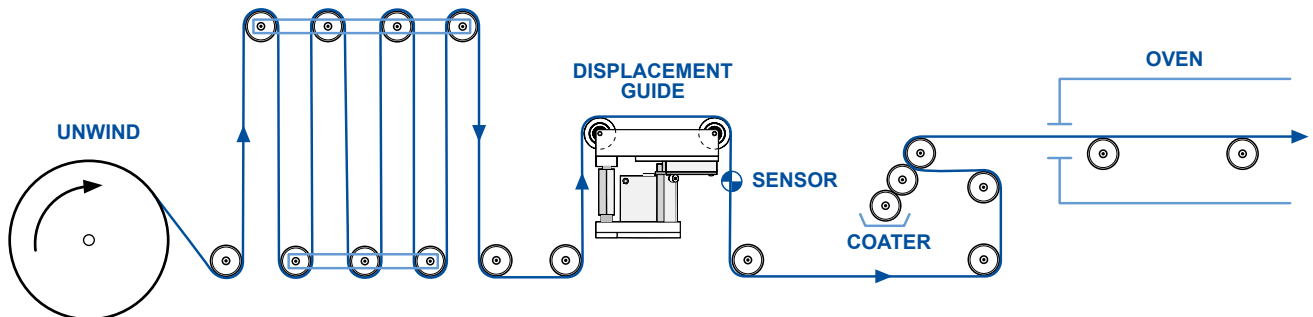

GUIDING INTO COATING

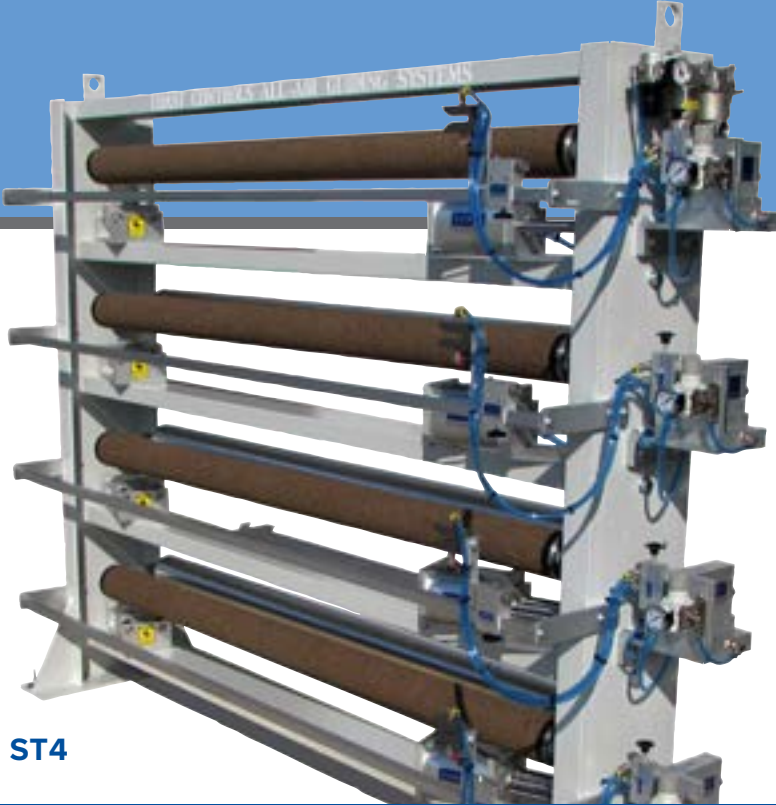

ST4

Used in the middle of the converting process, **Steering Guides** compensate for web errors, especially during long entry spans.

We design four steering guide systems. Custom-engineered, fabricated guides and mounting stands are readily available upon request.

They are either solid aluminum plate, clear anodized finish, or steel channel construction painted to the customer's specification. All come equipped with stainless steel hardware, low friction ER style bearings, and Auto Centering as standard features.

WEB PATH CONFIGURATIONS

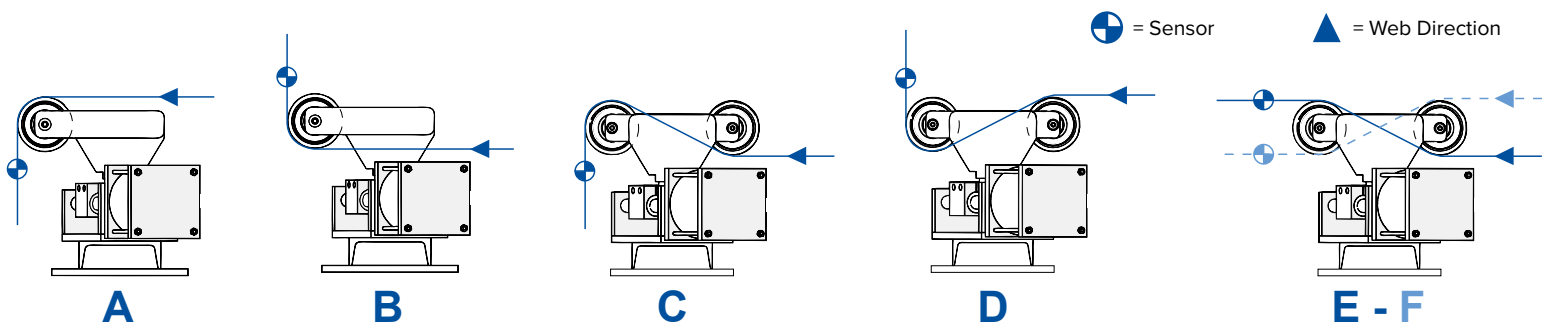

REQUIREMENTS FOR STEERING GUIDE APPLICATION

- Must be installed after a long, free-entering web span to prevent wrinkling. A web entry span of at least 2x the maximum web width must be maintained.
- The pre-entry span must be shorter than the entry span.
- The preferred exit span should be at least 1/2 to 1x the max web width.
- The airflow sensor must be securely mounted after the guide's exit roller (within the first 1/3 of the exit span).
- At least one idler roller must be located between the exit roller and the process (i.e. printing) to avoid guiding directly into a process.

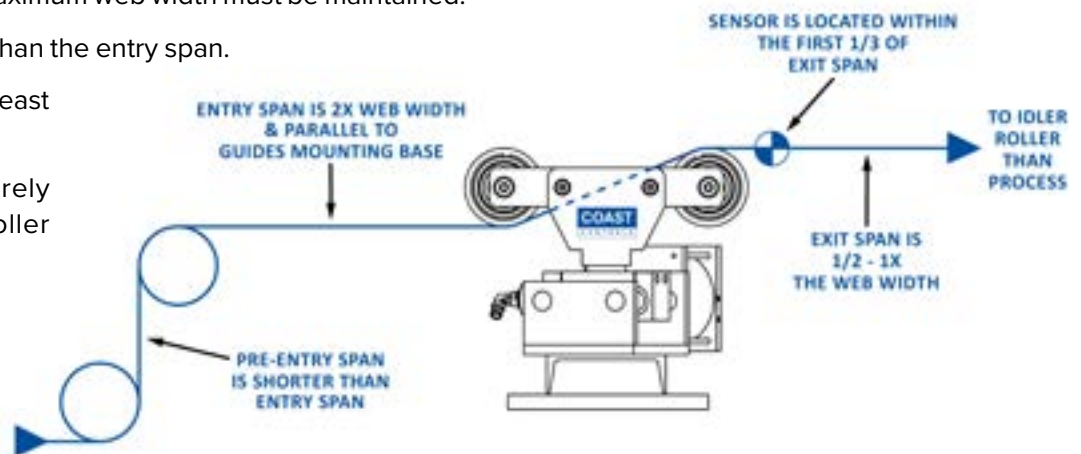



RS1-75

Web widths up to 8 in (203.2mm)

Roll Face 8 in to 10 in (203.2 – 254mm)

Roller Diameter 2 in to 2.5 in (50.8 – 63.5mm)

The **RS1-75** guides are compact steering guides ideal for the narrow web industry. They feature a single raceway assembly with 3/4-inch race rods and are powered by a 4 inch (101.6mm) diameter air cylinder.



RS1-10

Web widths up to 15 in (381mm)

Roll Face 15 in to 18 in (381 – 457.2mm)

Roller Diameter 2.5 in to 3 in (63.5 – 76.2mm)

Our **RS1-10** units feature a single raceway assembly with 1 inch (25.4mm) diameter race rods and are powered by a 5 inch (127mm) diameter air cylinder. This is one of our more popular models.



RS2-75

Web widths up to 30 in (762mm)

Roll Face 21 in to 35 in (533.4 – 889mm)

Roller Diameter 2.5 in to 4 in (63.5 – 101.6mm)

The **RS2-75** models feature a dual raceway assembly with 3/4 inch (19.05mm) race rods and are powered by a 5-inch diameter air cylinder.



RS2-10

Web widths up to 130 in (3302mm)

Roll Face 40 in to 140 in (1016 – 3556mm)

Roller Diameter 3 in to 8 in (76.2 – 203.2mm)

The **RS2-10** machines are a robust steering guide ideal for the medium to wide web industry. They feature dual raceway assemblies with 1 inch (25.4mm) race rods and are powered by 5, 6 or 8-inch diameter air cylinders.

STEERING GUIDES APPLICATIONS

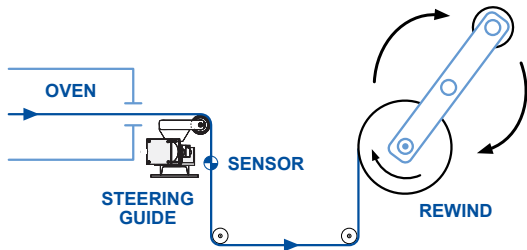

GUIDING FROM AN OVEN

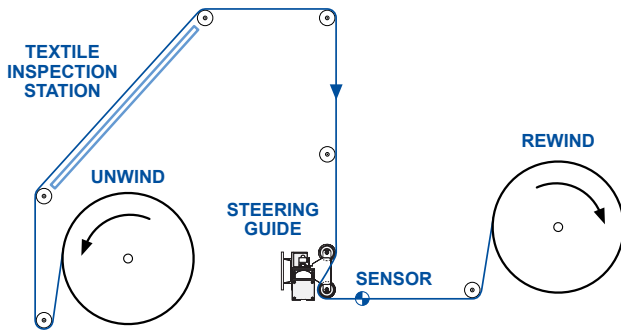

GUIDING ON AN INSPECTION MACHINE

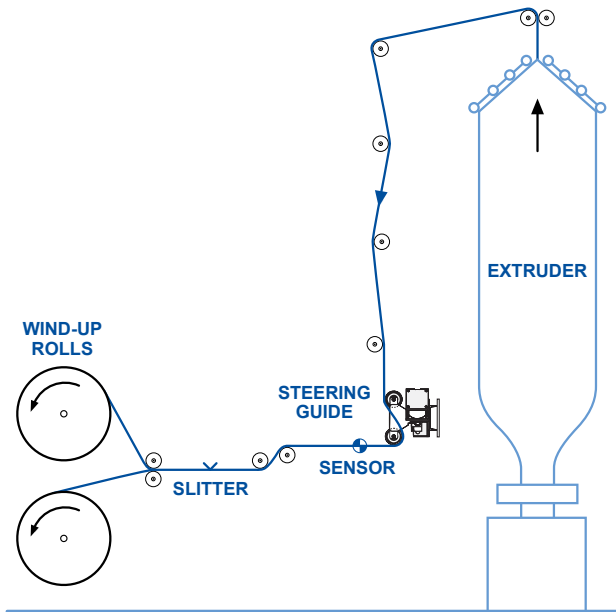

GUIDING INTO SLITTING & WIND-UP ON A BLOWN FILM EXTRUDER

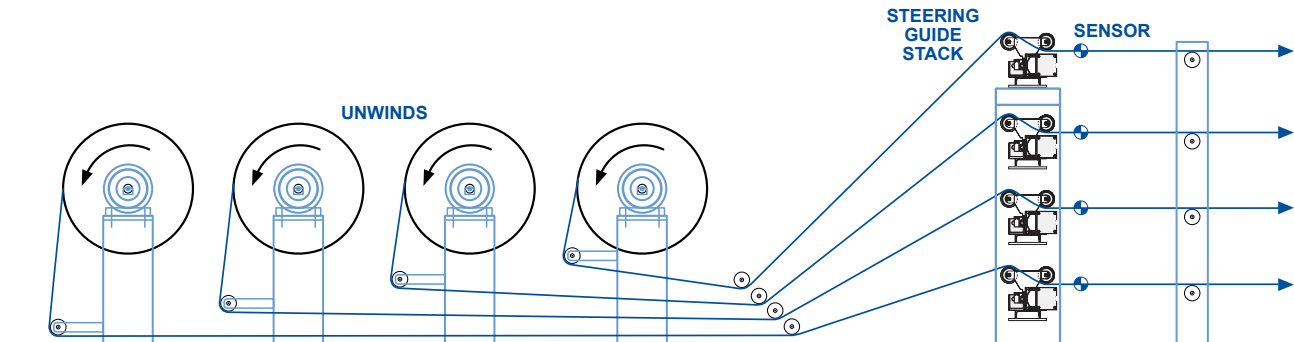

GUIDING FOUR WEBS ON A MULTI-WALL BAG MACHINE

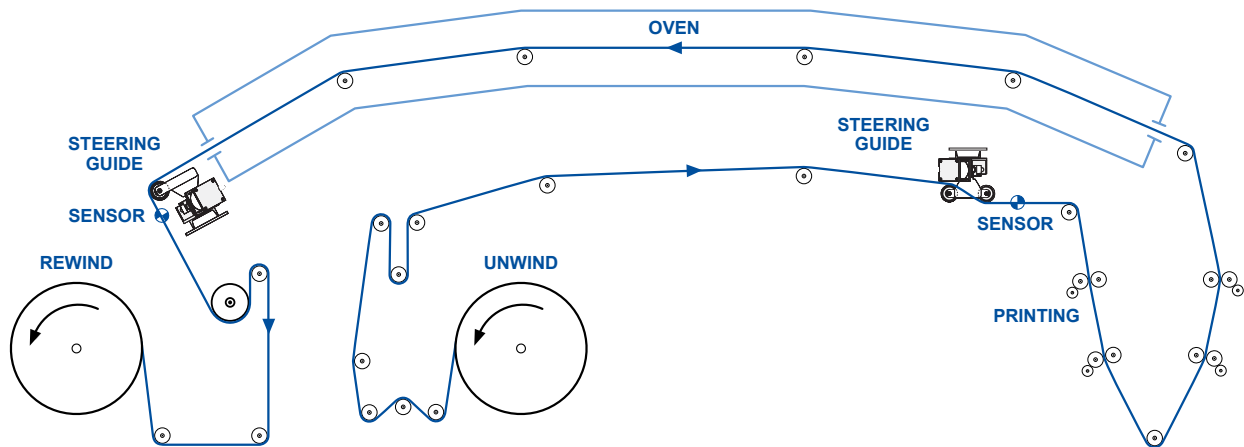

GUIDING INTO PRINTING & REWIND ON A FLEXOGRAPHIC PRESS

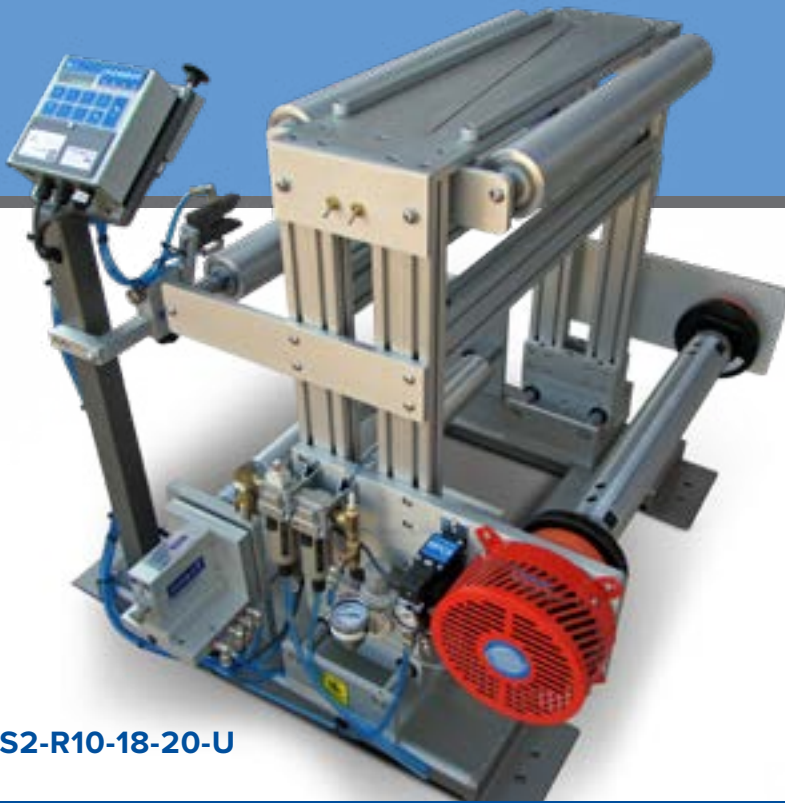

SRS2-R10-18-20-U

Coast Controls **Unwind** and **Rewind guides** are combined with Montalvo tension controls to provide a complete system that is sure to meet your application's needs.

They come pre-piped, mounted on custom stands, and equipped with raceway assemblies. Dual shifting idler rollers are standard with all shifting roll stands to insure a proper web plane is maintained through the sensor.

WEB PATH CONFIGURATIONS

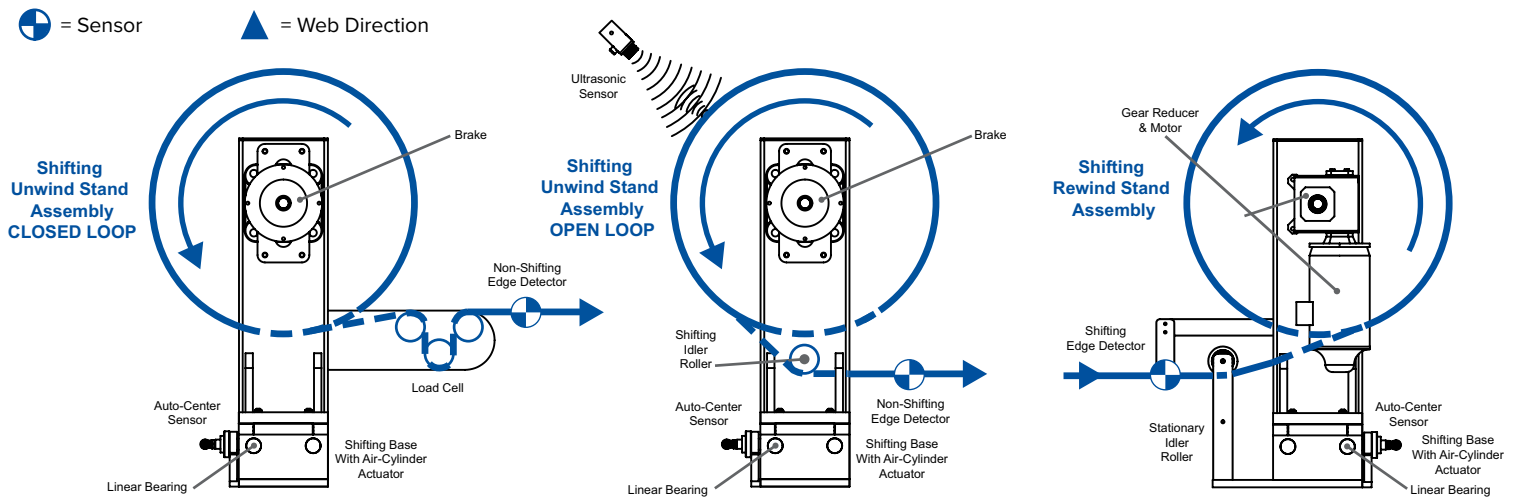

REQUIREMENTS FOR WINDING GUIDE APPLICATION

UNWIND:

- At least one fixed idler roller is attached to – and moves in unison with the unwind stand to keep the material on a constant plane through the airflow sensor as the diameter of the unwinding roll decreases.
- The airflow sensor mounts to a stationary part of the machine, independent of the shifting stand, and does not move during guiding.

REWIND:

- A fixed idler roller is mounted independently of the rewind stand between the airflow sensor and the rewinding roll.
- Airflow sensor is attached to and moves in unison with the rewind stand to maintain a constant plane of the web through the sensor as the diameter of the rewinding roll increases.

Coast Unwind and Rewind Guiding Systems combined with Montalvo tension & torque controls provide a complete turnkey package that is sure to meet the needs of your application.



SRS1

Max load up to 200 lbs (90.7 kgs)

Max Web Width 20 in (508mm)

The **SRS1** Series is a cantilevered unwind or rewind stand and is perfect for narrow web applications, such as pharmaceutical and food packaging industries.



SRS2

Max load up to 5000 lbs (2268 kgs)

(Full roll weight + machine weight on linear bearings)

Our **SRS2** model is a shifting unwind or rewind stand accurately guides various web widths, while easily supporting heavy loads.



SRS4

Max load up to 7500 lbs (3402 kgs)

(Full roll weight + machine weight on linear bearings)

The **SRS4** unwind or rewind stand is a rugged unit and features the capability of shifting heavy loads with ease.

If you need more information or questions regarding your winding needs, feel free to call or email us.

941.355.7555 • sales@coastcontrols.com

Are you tired of:

- Fried circuit boards
- Burned out motors
- Leaky hydraulics
- Obsolete spare parts
- Needless downtime
- Scheduling routine maintenance
- Expensive replacement parts

Maybe it's time we did something about it.

BENEFITS OF RETROFITTING

- Accurate & Dependable — backed by our full **10-year guarantee** and **100% Satisfaction Guarantee**
- Requires no routine maintenance or spare parts
- Simple to understand and install — attaches directly to existing guide frame

BRPP50 Basic Package



BRP & CRP 50

Max load up to 2000 lbs (907.1 kgs)

BRP & CRP 60

Max load up to 3000 lbs (1360.7 kgs)

CRPP60 Complete Package



RETROFIT REQUIREMENTS

- Existing guide must be in good mechanical condition and move freely (without bind).
- Guide must be properly located and installed on a web processing machine.
- The air-flow (edge) sensor must be securely mounted after the guide's exit roller and within the first one-third of the exit span.
- It may be necessary to relocate the existing guide to obtain desired guiding results.

ROLL STAND CONTROLS



RSC60-6

RSC60

Max load up to 3000 lbs (1360.7 kgs)

Bore Diameter	6 in (152.4mm)
Stroke Length	4 to 6 in (102 to 152mm)

Our **RSC** models are completely assembled and pre-piped Roll Stand Control System. They are designed to attach directly to an existing shift-able unwind stand and automatically position an unwinding roll of material to a predetermined point as the web enters a process. The sensor mounts independent of the stand (after the last shifting idler) and does not move during the unwind process.

This guiding assembly component is ideally suited for new machines as well as retrofits (upgrade) on older machines.

No electronics, No hydraulics means no problems. Easy to install and setup.

RSC80

Max load up to 5000 lbs (2268 kgs)

Bore Diameter	8 in (203.2mm)
Stroke Length	4 to 6 in (102 to 152mm)

TYPICAL RETROFIT COMPONENTS INCLUDE:

- **Model 10A Friction-Free Proportional Servo Controller**
- **Two Stage Cartridge/Coalescing Filter with Precision Regulator, Pop-Up Indicator and Gauge Assembly**
Cartridge(0.5 μ) / Coalescing(0.01 μ)
- **Piston Type Actuator**
Engineered with 1/2 PSI breakaway
3", 4", 5", 6" and 8" bores available in various strokes
- **Raceway Bearing Assembly**
3/4" diameter bearing shafts up to 1.5" diameter for heavier applications
- **Carrier Block and Auto Center Assembly**
- **Auto Center Assembly with 3-Way Valve**
- **Airflow "Edge" Sensor**
Various gaps for different web thicknesses.
Paddle type feeler sensors also available
- **Model 104 Mounting Bracket and 1-inch Square Bar**
Course and Fine adjustments
Remote controlled brackets also available



RSC80-6

How much air pressure does a Coast system require to operate?

The Two-Stage filter package requires a minimum of 60 PSI to seat the filter bowls. After the filter bowls are seated, the precision regulator will reduce the air to a normal operating range of 5 to 8 PSI.

How much air does a Coast system consume?

Under normal operating conditions, normal usage is approximately 1.5 CFM.

Air is expensive! What is the utility cost to operate a Coast system?

Since a Coast system will consume approximately 1.5 CFM at 5 PSI it depends on the air compressor's efficiency. For Example, at 95% efficiency and a \$.08/KWH rate, usage is approximately \$0.0235/hour!

Does Coast provide training and installation?

Coast technicians can provide on-site training and installation, but not necessary. Most systems require a few bolts to install and the training is as easy as 1-2-3 as there are only three (3) settings to achieve a perfect web guide or your application.

Do I need to stock spare parts?

No. Coast systems are built to last, but if a part is needed, 99% of all components are on the shelf and can ship the same day.

How does a Coast system perform with Clear or Metalized film?

Perfect! Since only a small stream of air is used to detect the material's edge, it doesn't matter if the material is clear, opaque, dense or reflective.

How well does the system work in Hot, Humid and Dusty environments?

Flawlessly! The system takes in cool compressed plant air and never vacuums or draws from the outside air such as other sensors on the market. Therefore, the sensor is essentially self-cleaning.

What routine maintenance is required?

None. The two-stage filter package relies on a pop-up indicator to let you know if the filter elements have been compromised which can cause irregular movement in the system.

What are the electrical requirements?

None. The system is powered entirely by high-pressure plant air, then regulated to a lower operating air pressure.

ELECTRIC WEB GUIDING



In cooperation with Selectra, Coast Controls is pleased to offer a complete line of electronic web guiding systems in addition to the precise and durable all-air systems. Producing the latest in technology electromechanical web guiding systems provides us the ability to serve our customers for virtually all applications.

1. Guiding from a printed line or registration mark
2. Shifting heavier roll stands
3. Economical retrofit packages and center guiding
4. Economical guide/follow assemblies
5. Extra-wide gap sensors for thicker materials
6. Compact designs for applications with space constraints

SPECIFICATIONS & FEATURES

- User friendly 3.5-inch LCD touch screen interface with web width data, and PID algorithm to accelerate reaction time and correction with dead zone
- Circuitry provides superb reaction time and is faster than most competitors
- Up to 7000N Actuator uses a ball screw, anti-rotation, integrated limit switches, and integrated servo center
- Numerous sensor options to read virtually any material
- Adjustable settings for left/right edge control
- Automatic gain and level adjusting
- Settable offset from operator interface
- Sensitivity 0.01 mm (0.000378 in.)
- Max correctable error ± 10 cm (3.937 in.)
- Airflow cleaning protection device available upon request





CONTROL PANEL

LCD Touch Screen with user-friendly interface

- LCD touch screen operating panel with user-friendly interface
- Digital driver to control the correcting motor
- Sends a correction signal to linear actuator and servo center
- RS-485 communication
- PID algorithms provides a high degree of control in real-time
- Automatic sensor motorization to measure material width
- Generating power supply: 24V
- Reflective photocells, ultrasonic sensors, or infrared sensors regulate the measured errors

SELEGUIDE SENSORS

Optical, Ultrasonic & Infrared

- **Optical sensor** for reading contrast or printed line
- **Ultrasonic sensor** best for reading transparent materials
- **Infrared sensor** for non-woven, tissue, napkins, diapers, etc.
- Power supply: 24V with RS-485 connection
- Proportional band: 20 mm (0.787 in)
- Electric noise protection
- Standard cable: 5 m (16.4 ft.)
- Longer forks available upon request



SELEGUIDE ACTUATORS

Max force up to 7000N

- Trapezoidal or Ball Screws
- Built strong to withstand hard conditions while maintaining very high precision
- Same capabilities in both directions
- Internal limit end switches and servo center sensors



OSCILLATION (PNEUMATIC & ELECTRIC)

A variable speed oscillator is used to offset the “Gauge Band” buildup on certain guiding applications to prevent roll slippage.

The electric motor combines 90 VDC accuracy with a 115 VAC Speed control. The fully adjustable cam arm gives you the ability to set the desired offset anywhere between 0 to 1”. This combination results in a compact easy to use package capable of varying speeds from fast to slow with 0-1” of oscillation.

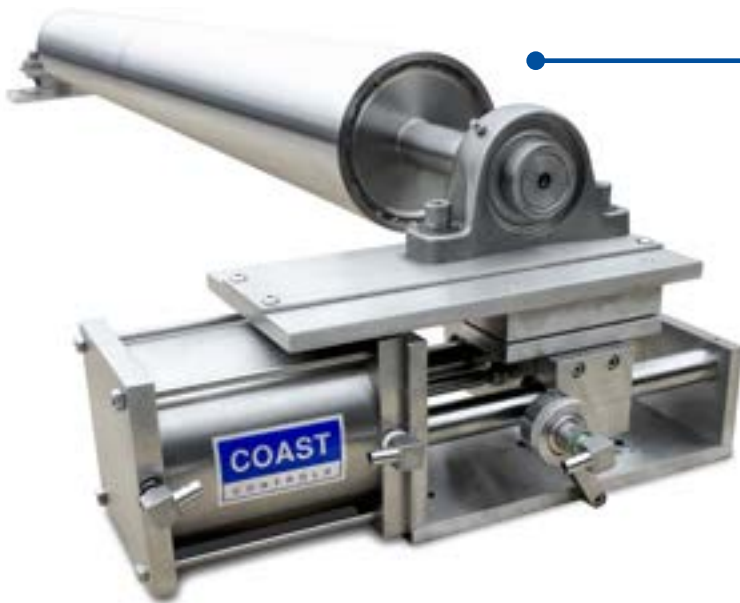
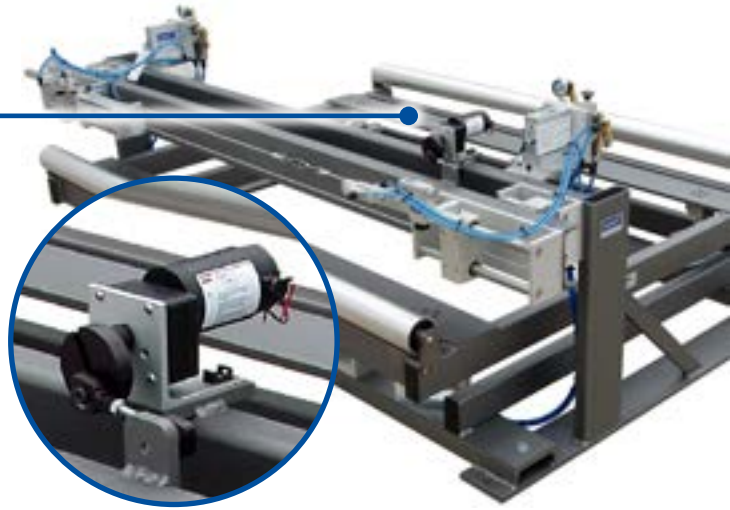

END PIVOT GUIDE

Typically used with conveyor belts, these End Pivot Guides (EPG) are designed for standard to rigorous environments including high heat, high tension, and wash down applications.

They use a standard fork sensor or a paddle sensor to detect the location of the belt edge. EPG systems are available in standard materials as well as complete stainless steel.

CUSTOM MOUNTING STANDS

Using state-of-the-art equipment, we can manufacture custom mounting stands to accommodate non-standard guiding applications. All engineering and manufacturing is done on-site, which allows us to build a custom stand to fit your guiding needs. Whether it's as simple as adding additional idler rollers or complex configurations, Coast can handle it.

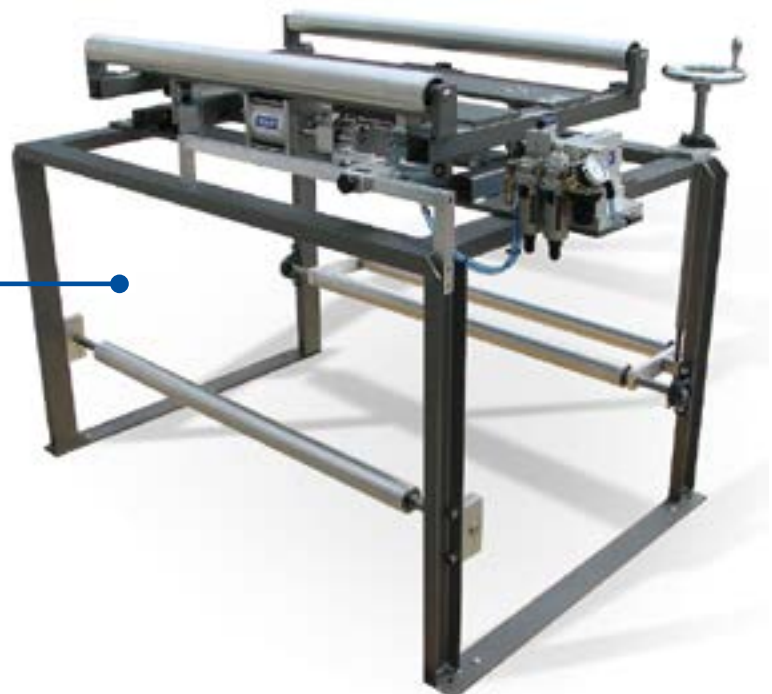

CENTERING GUIDES

For centerline guiding applications, the CG2 works in conjunction with other Coast Intermediate Guides to align the web's imaginary centerline on materials with varying web widths. The moving Sensor Positioning Assembly can automatically adjust up to 20 in of web width change and sensors will automatically retract when put into "auto-center".



REMOTE SENSOR POSITION ASSEMBLY

For guiding applications in hard to reach areas, a Remote Sensor is ideal to change the sensor location and accommodate for web width changes.

The electronic switch can be connected to a PLC or manually operated to relocate the web sensor.

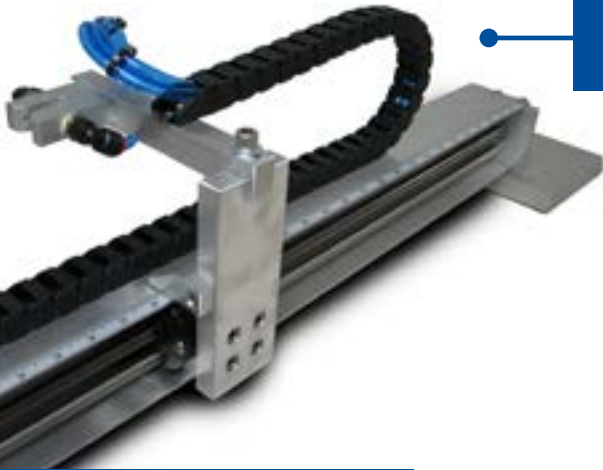

ENCLOSURES

NEMA-4X vented industrial control panel enclosure is UL-Listed and provides the perfect protection for Coast's System Controls, Gauges, and Regulators from harsh environments like dirt, wash down, splashing liquids, and corrosive agents.



SPLICE TABLES

Attaching a splicing table to a standard displacement guide or mounting it independently, allows the operator to firmly clamp the leading end of a new roll to the trailing end of an expired roll.



ADDITIONAL PRODUCTS & OPTIONS

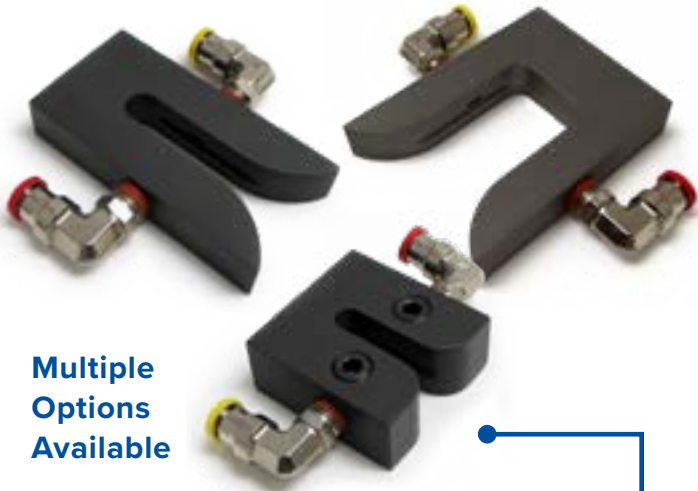

Multiple
Options
Available

AIRFLOW SENSORS

These use continuously positive airflow to detect the web error and misalignment. The change in air pressure acts as the signal to the servo controller. This sensor also keeps itself free of dust and other foreign matter.



Individual
Parts
Available

2-STAGE FILTER PACKAGE

This is a complete two-stage cartridge / coalescing filter package with auto drain, pop-up indicator, 0-15 precision regulator and gauge. It is used to control and filter the air PSI to the servo controller.



PADDLE SENSOR

Used when web materials are either too thick or porous to use with a stream of air and there is no problem with paddle making contact with the web's edge.



SERVO CONTROLLER

Our all-air guiding applications are equipped with a Servo Controller. Working in between the air-flow sensor and actuator, the controller converts the signal sensor to a higher pressure for the air cylinder.



Differing
Sizes
Available

AIR CYLINDER

All our air cylinder components are constructed out of anodized 6061-T6 aluminum. The connecting rod has a 7/16-20 UNF thread that comes with a locking nut.



Coast makes 3 types of rollers for your converting process: **Aluminum**, **Steel** and **Stainless Steel**. Here you'll find helpful information.

Each type of roller comes in a number of coating options, allowing us to make a specific roller for your exact need. See our Roller Options page to view some of the coating options.

If you need more information or questions regarding your idler needs, feel free to call or email us. **941.355.7555** • sales@coastcontrols.com

Since 1992, we have been manufacturing high-quality idler rollers, making them individually, or as part an innovative web guide. They are constructed out of various materials and designed to fit any specified machine.

Today, we engineer idlers for a wide range of converting applications. No matter what type you are looking for, we guarantee high quality, precision-made rollers that are the perfect fit for your industry and all are dynamically balanced according to your specifications. Most of our idler rollers will be delivered within 1-2 weeks.

When ordering from Coast Controls, you are getting a product you can rely on for years to come. That's why we offer the same 100% satisfaction guarantee that we have placed on our all-air web guiding systems for over 25 years.

DEAD SHAFT VS. LIVE SHAFT

When you decide to purchase idlers, you will need to choose either a dead shaft or a live shaft. Each has its key advantages and the decision depends solely on your unique manufacturing requirements.

DEAD SHAFT:

- Bearings are installed **INSIDE** the body
- Inside bearings mean minimizing roller deflection
- Less expensive
- Lower rolling inertia

LIVE SHAFT:

- Shaft ends are fixed to the roller body
- Self-aligning bearings can be used
- Withstands harsh & high-temperature environments
- Holds up to higher workloads



ALUMINUM ROLLERS

Half the weight of steel. Best for low web tension and minimal web wrap applications.

- 6061-T6 grade aluminum tubing
- 32 Ra finish on roll face
- Dynamically balanced to ISO grade G6,3
- Straightness over roller face width within the greater of 0.002" in. or 0.0005" in/ft of face length

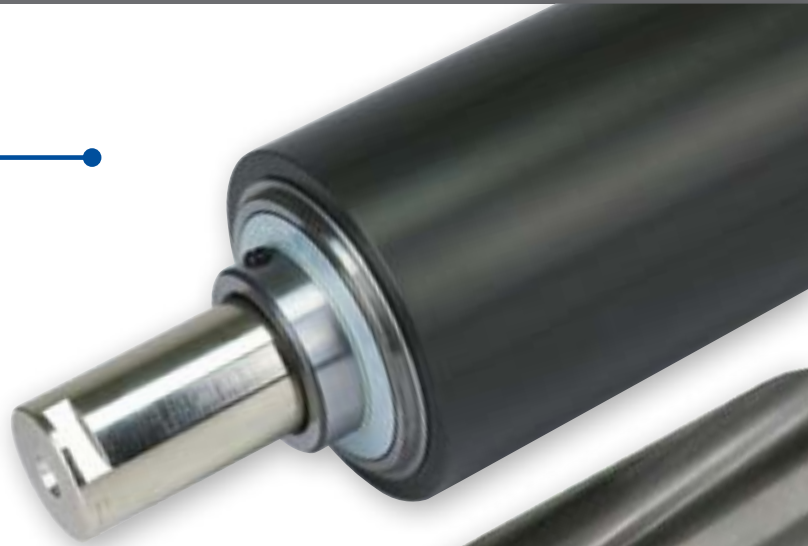

STEEL ROLLERS

Withstands substantial loading from nips, wrap angle and high web tension. Tolerates temperatures up to 212°F with a lesser thermal expansion rate than aluminum.

- 1045 grade steel tubing
- 32 Ra finish on roller face
- Dynamically balanced to ISO grade G6,3
- Straightness over roller face width within the greater of 0.002" or 0.0005"/ft of face length



STAINLESS STEEL ROLLERS

Perfect for corrosive and high moisture environments. Higher wear resistance than steel. Exceptional performance in food and medical environments.

- 304 grade stainless steel tubing
- 32 Ra finish on roller face
- Dynamically balanced to ISO grade G6,3
- Straightness over roller face width within the greater of 0.002" or 0.0005"/ft of face length



ROLLER COATING OPTIONS

We can be customize rollers with extra features or outer coatings. Listed below are some of the options we offer but are not limited to the following. If there is an idler attribute you need that you do not see listed here, please feel free to inquire about it. We strive to meet all of our customer's needs.

Air Entertainment Grooves

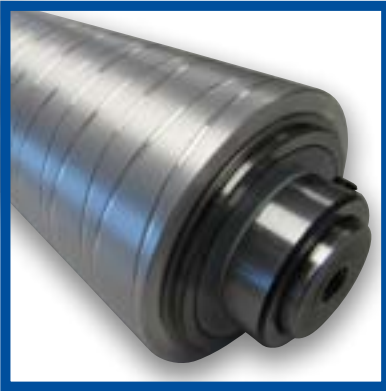

Hard Coat Anodized

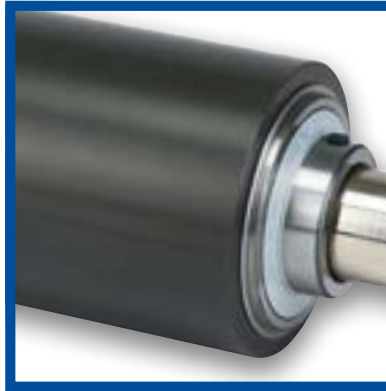

Knurled

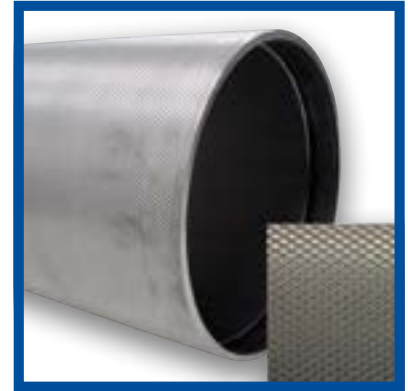

Plasma

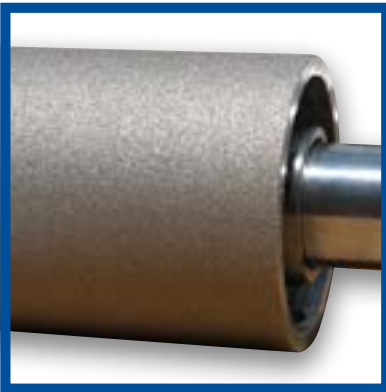

Polyurethane



Reverse Crown

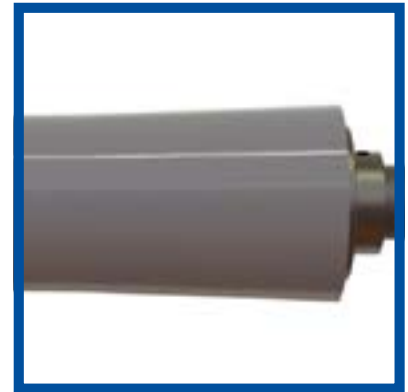

Rubber Cork Tape

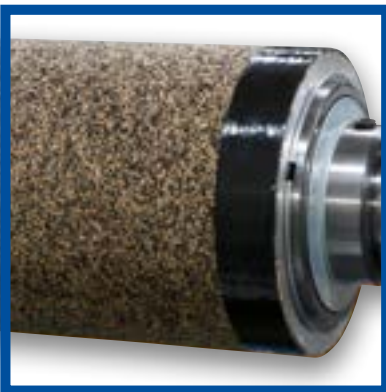

Tension Sensing

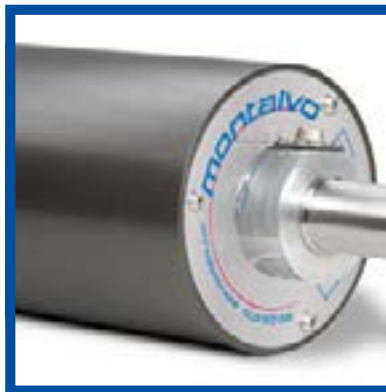

Urethane

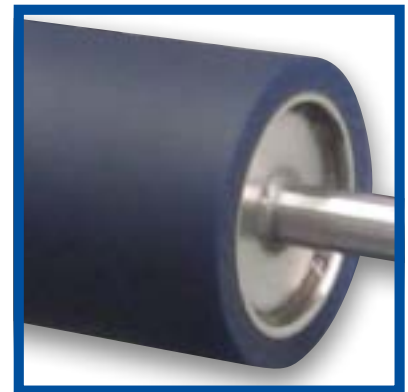

QUALITY ASSURANCE

Coast Controls All-Air Guiding Systems are 100% guaranteed to perform to the Customer's complete satisfaction when installed as recommended. The simplified design and dependability of the friction-free All-Air Servo Controller and related components, allows Coast to provide a 10-year warranty on pneumatic guiding systems. The warranty starts the date of shipment and covers defects or premature wear of any unit component.

To ensure years of trouble free operation, tandem mounted particulate and coalescing air filters are included with each guiding system. Contact Coast's Technical Support Department for various answers to warranty or other questions.

UNITED STATES SALES MAP

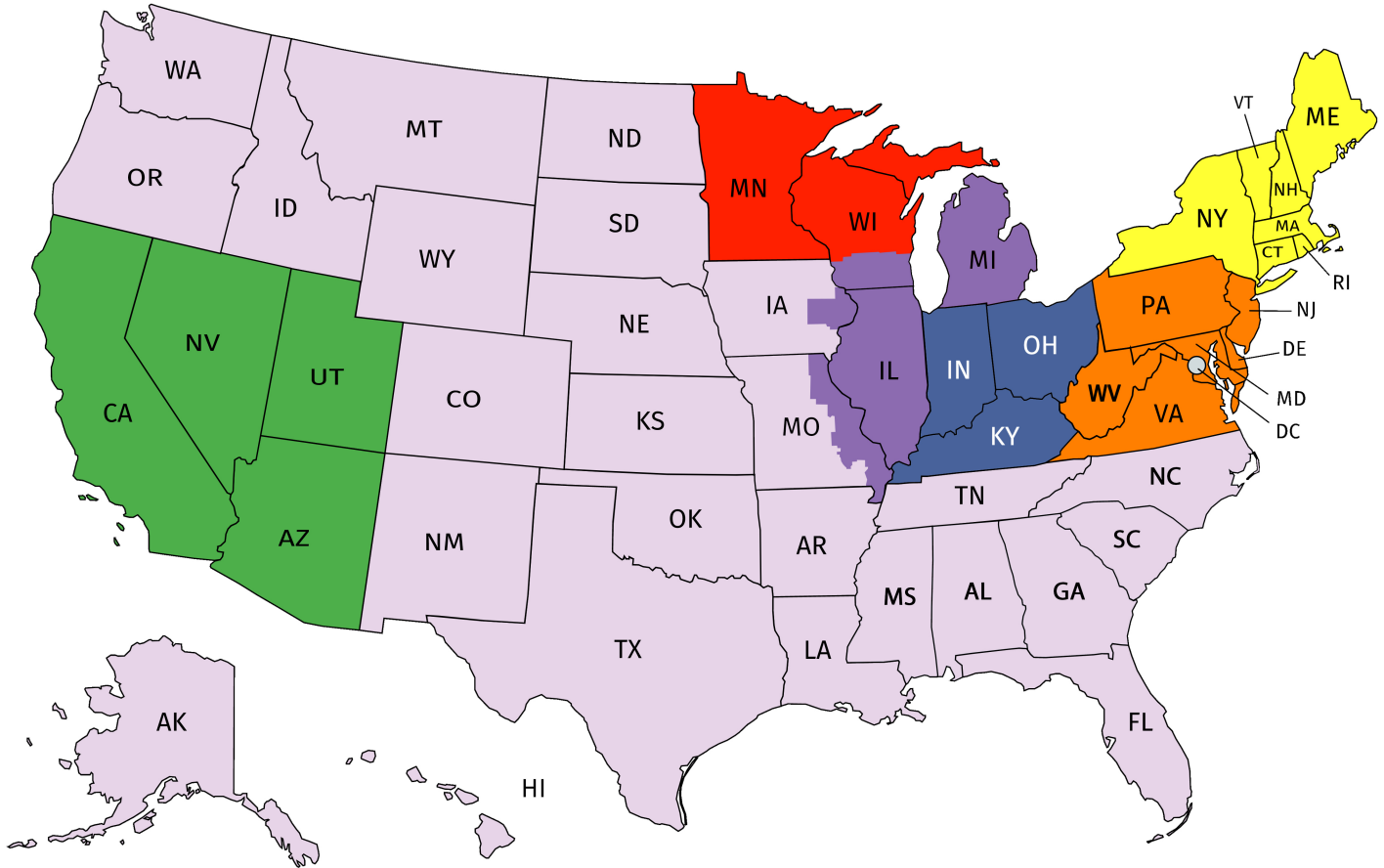

Kyle Koontz
M: (941) 993-7709
O: (941) 355-7555 x111
F: (941) 359-2321
kkoontz@coastcontrols.com

Ken Davis
M: (717) 360-8874
O: (717) 359-0400
F: (717) 359-0442
KenDavis@atlantechindustrial.com

Montalvo Corporation
O: (800) 226-8710
cs@montalvo.com

Mike Carroll
M: (805) 312-5947
mike@beltlink.com

Jeff Messenger
M: (902) 301-5637
jeffm@messengersales.com

Nick Herman
M: (847) 212-6965
O: (630) 289-8000 x11
nickherman@motionworksinc.com

Dean Grosel
M: (440) 478-8850
sales@grosel.com



7500 Commerce Court, Sarasota, FL 34243
941.355.7555 • 800.513.2345 941.359.2321
sales@coastcontrols.com