

**VLC-Series**

Individual End Tension Load Cells

New for 2020... Multi-Tow Tension Monitoring and Control



IP54

**Montalvo VLC Series Individual End Tension Load Cells**

The all new Vanguard Load Cell - VLC (a component of the Montalvo Vanguard System) is a specially designed load cell for providing precise, repeatable tension measurement of individual tows. Interchangeable pulleys combined with a narrow, stackable profile, and a wide range of load rating options ensures the VLC Series meets the requirements of practically any process running tows or single strand materials (carbon, glass, textile, wire, etc).

Designed and built for the unique and often low-tension requirements of these materials, achieve precise tension measurement from start to finish for higher quality end product and less scrap.

**Features and Benefits**

- ▶ Wide Sensing Ranges - from 20g to 10kg
- ▶ Pre-Calibrated – Just Install and Go
- ▶ Built-In Amplifier for Easy Connection to Existing I/O
- ▶ Precise, Repeatable Tension Measurement of Individual Ends
- ▶ High Overload Protection
- ▶ Interchangeable Pulleys/Rollers to Match Material Widths
- ▶ Compact, Stackable Design to Meet Process Space Requirements
- ▶ Produces Superior Tension Signal for Maximum Accuracy
- ▶ Used for Providing Continuous Tension Indication or Connect to a Control Scheme to Produce Automated, Continuous Closed Loop Tension Control System

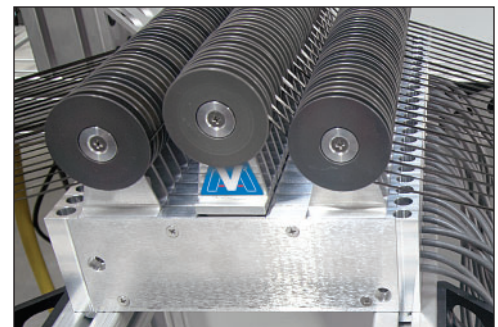

Dimensions

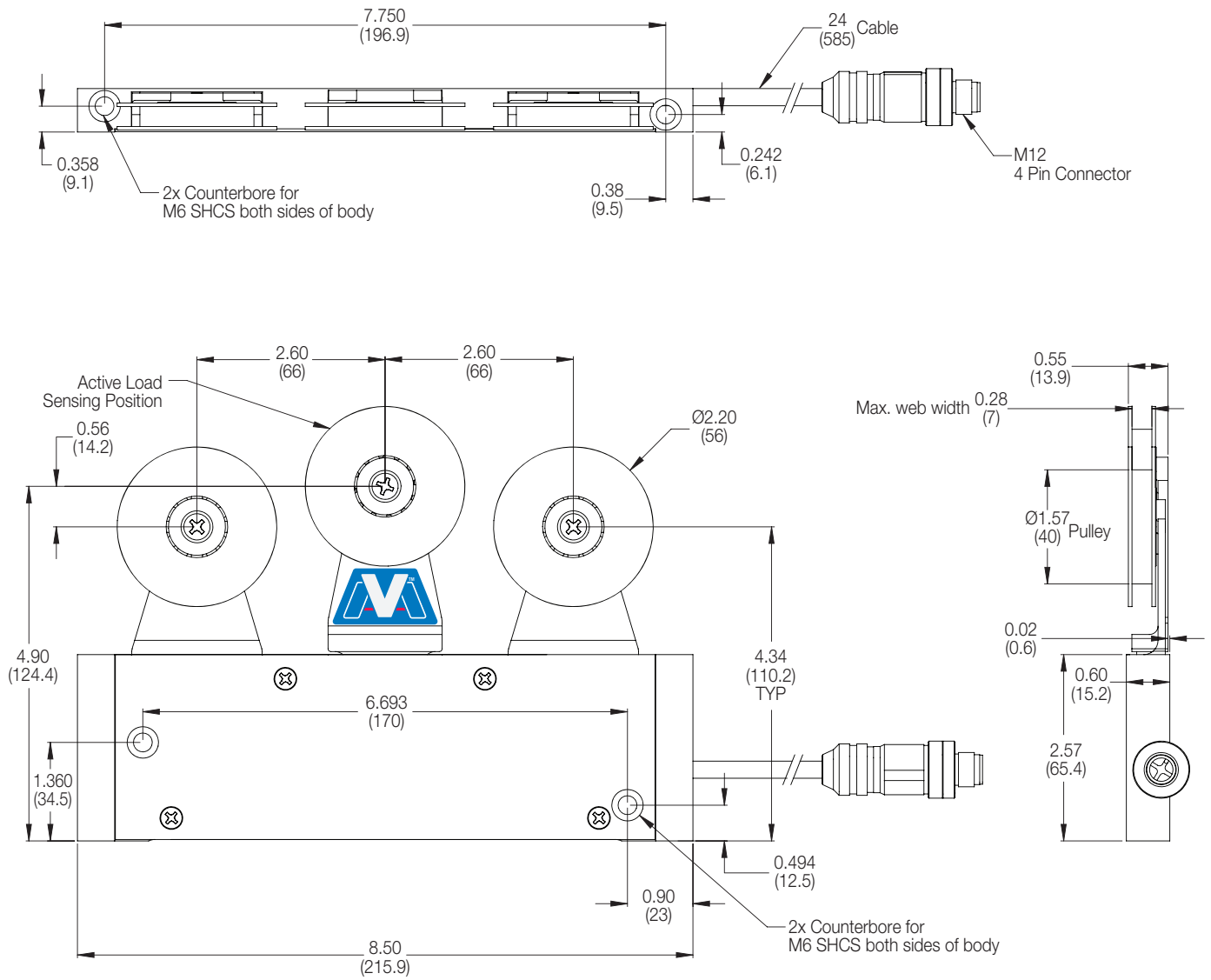
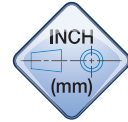

How It Works

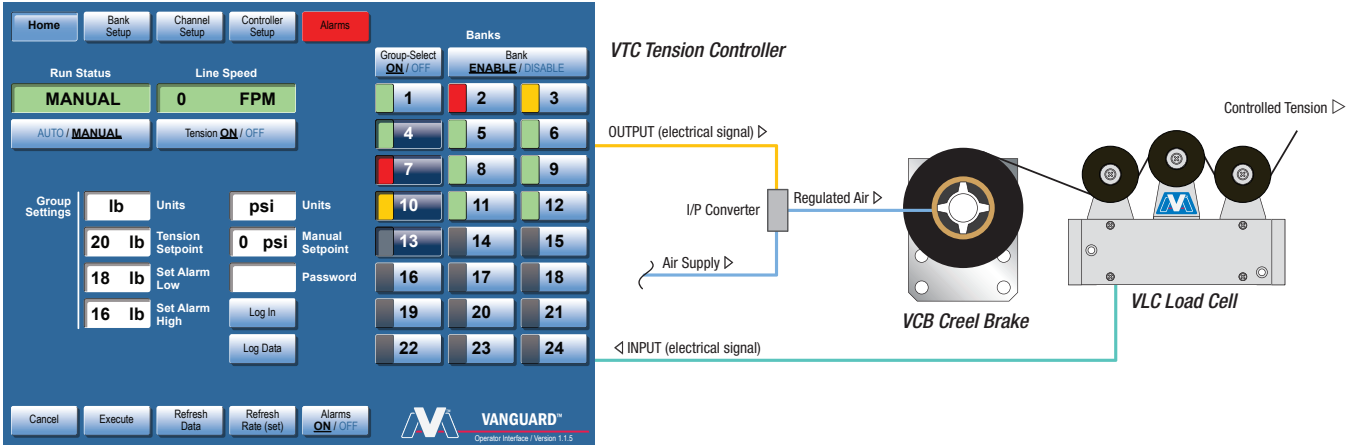

**Specifications**

Power (with on board amplifier - standard)	24 VDC
Power (without on board amplifier - option)	5 VDC
Output-Nominal	25-50 mV/V
Gauge Resistance	80-130 Ω
Gauge Type	Half Bridge Semiconductor Strain Gauge
Non-Repeatability	±1.5 % full span
Non-Linearity and Hysteresis (combined)	±1.5 % full span
Load Rating	VLC-02 0.44 lb (200 g)
	VLC-08 1.77 lb (800 g)
	VLC-12 2.65 lb (1.2 kg)
	VLC-50 11 lb (5 kg)
	VLC-100 22 lb (10 kg)
Overload Stops	110% of Load Rating
Overload Rating	150% of Load Rating
Axial Overload Rating	20% of Load Rating
Classification	IP54
Temperature - Operating Range	-4 to 150°F (-20 to 70°C)
Temperature Coefficient (% per degree)	0.02 (0.01) typ.
Deflection	0.008 to 0.015 in (0.203 to 0.381 mm)
Body Finish	Aluminum
Roller Finish*	Anodized Aluminum

\*Optional roller materials, finishes, and profiles available. Contact Montalvo for more information.



# The Montalvo VANGUARD™ System (MVS)

The patented VANGUARD™ System is Montalvo's flagship closed loop tow and tape tension control technology system, leading the way in precise, uniform, consistent, automated tension control.

## Tension Measurement (input)

Continuous, precise tension measurement directly from your tow. The VANGUARD Load Cells (VLC) feature Montalvo's industry-leading load cell technology for sensitivity, reliability, and repeatability.

- Wide Sensing Ranges – from 20g up to 10kg
- Pre-Calibrated (Just Install & Go)
- Built-In Amplifier for Easy Connection to Existing I/O
- High Overload Protection
- Precise Tension Measurement

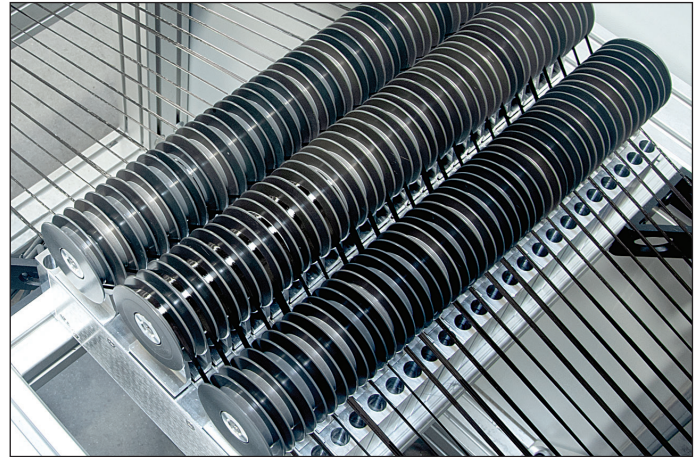

## Tension Control (process)

A single interface for automated control, indication, and data collection of every tow in your process. Montalvo's VANGUARD Tension Controller (VTC) is easy to set up and operate, automatically and precisely maintaining set tension from start to finish.

- Low/High Tension and Tow Break Alarms
- Pre-Configured for Your Application
- Single Interface for Managing Every Tow in Your Process
- Adjustable and Expandable Tow Counts



## Torque Control (output)

Smooth, consistent, precise torque control for maximum process capability. Montalvo's VANGUARD Torque Control offers three different torque control options depending on the requirements of your application.

- Wide Torque Ranges and Tension Profiles Capable of a Wide Variety of Materials and Tensions
- Easy, Hassle-Free Installation
- Long-Lasting, High-Quality Performance
- Retrofit Capable – Upgrade Your Existing Creels



	207-856-2501 / 800-226-8710	
	+86-21-52188010	
	+45 75 57 27 11	
	+49 (0)511 760 691 41	



The Montalvo Corporation

EST. 1947

# montalvo

Better Web Control®

50 Hutcherson Drive, Gorham, Maine 04038 USA  
Fax: 1-800-644-5097 / 207-856-2509

1-800-226-8710 / info@montalvo.com / www.montalvo.com

Technical details subject to change without notice. VLC-US-03 © Montalvo