

PDA & PDA-R

Remote Range Control Valves

**Montalvo PDA & PDA-R Remote Range Control Valves**

The Montalvo PDA and PDA-R valves allow direct remote control of brake cylinder operation. Brake cylinder modules can be controlled simultaneously through one unit. Brake operators can turn cylinders on and off from their control panels and thereby set brakes to run at different torques. Adjustments can be made remotely, relieving the operator of the task of removing the brake guard and working in an area that could be rotating and/or hot. The pneumatic actuation makes the system safe for explosion proof operating areas. All integral parts of the PDA-R are interchangeable with the PDA configuration.

Features

- ▶ Easy to install and operate
- ▶ Quick disconnect fittings
- ▶ Compact, convenient size
- ▶ Flexible mounting configurations
- ▶ Improved tension system resolution
- ▶ Remote operation for operator safety
- ▶ Improved torque sensitivity & brake control

Montalvo

PDA & PDA-R

Remote Range Control Valves

Dimensions

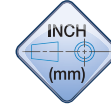

PDA

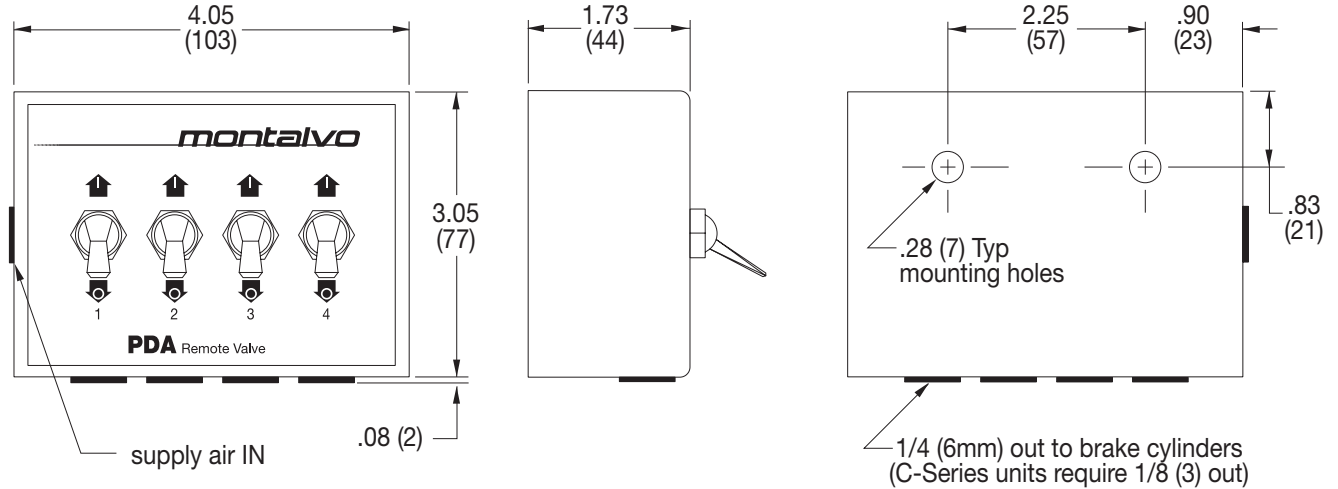

PDA-R

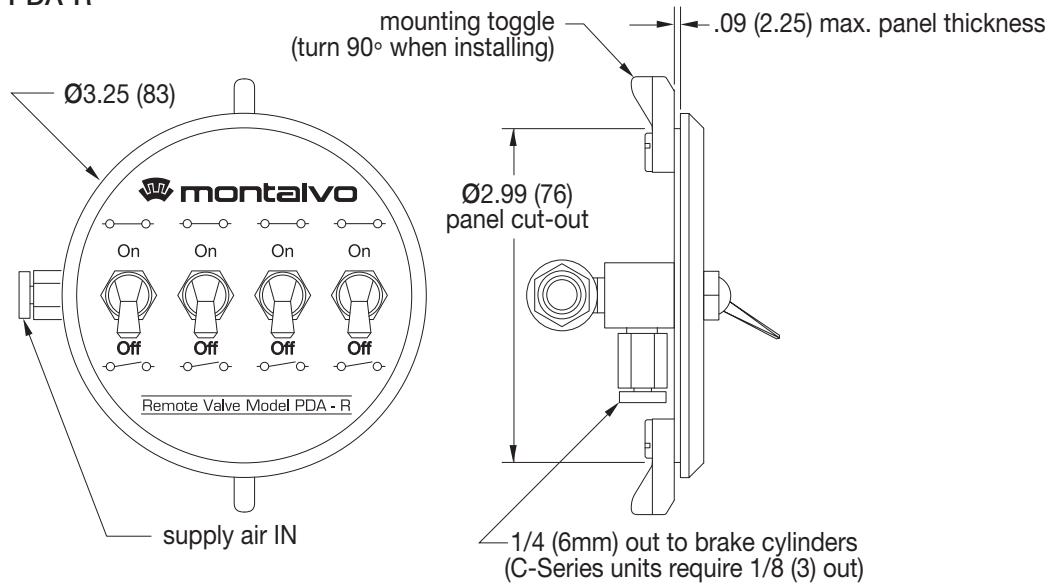

	207-856-2501 / 800-226-8710
	+86-21-52188010
	+45 75 57 27 11
	+49 (0)511 760 691 41



The Montalvo Corporation

EST. 1947 **montalvo**
Better Web Control®

50 Hutcherson Drive, Gorham, Maine 04038 USA

Fax: 1-800-644-5097 / 207-856-2509

1-800-226-8710 / info@montalvo.com / www.montalvo.com

Technical details subject to change without notice. PDAPDAR-US-01 © Montalvo